

Natural Computing

The Whole Story

Richard G. Shoup

“The good Christian should beware of mathematicians and all those who make empty prophecies. The danger already exists that mathematicians have made a covenant with the devil to darken the spirit and confine man in the bonds of Hell.”
-- St. Augustine

- Math and Theory
 - Boundary Math, Losp
 - Link Theory
- Language and Interface
 - Sandbox
- Architecture and Tools
 - PARTS, PARTS II
- Applications and Development
 - Stereo disparity, ARP, etc (w Was, Byz, others)
 - DRAM+FPGA, etc.

Computing - 50 years

- von Neumann architecture (Eckert)
- Turing-Church theory
- Algorithms
 - “A step-by-step problem-solving procedure”



Muhammad al-Khwarizmi

Building Computers Today

- silicon structures
- transistors
- gates, logic design
- register-transfer
- microcode
- assembly/machine code
- low-level language
- operating system
- application library
- high-level language
- user interface, application

“Basic” ZFC Set Theory (What’s wrong with this picture?)

$\forall x \forall y [(x = y) \leftrightarrow \forall z (z \in x \leftrightarrow z \in y)]$ (*extensionality*)

$\forall x \forall y \exists z (z = \{x, y\})$ (*pairing*)

$\forall x \exists y (z \in y \text{ iff } z \in x \wedge \phi(x))$ (*separation*)

$\exists x (\{y \in x \wedge \forall y \in x (S(y) \in x))$ (*infinity*)

$\forall x \exists y (z \in y \text{ iff } x \supset z)$ (*power set*)

$\forall w \exists s (s = \{y: \exists x \in w \wedge \phi(x, y)\})$ (*replacement schema*)

$\forall X \exists f (\forall x \in X - \{f(x) \in x)$ (*choice*)

The Whole Story

- Void/Nothing
- Distinction / Something / Selection
- Connection / Multiplicity / Linking
- Self-reference / Paradox-Memory -> Space-Time
- Relations -> Link Theory -> Quantum Mechanics

*"Things are entirely what they appear to be
and behind them ... there is nothing."
-- Jean Paul Sartre*

Logics

- 1-valued (Spencer-Brown, Kauffman, Bricken)
 - Void/1st Distinction => (NoExist)/True
 - Enough for most of classical logic
- 2-valued (Boole, Cantor, etc)
 - Redundant, not minimal
 - Express contradiction in arith, paradox in algebra
- 2-valued w imaginary (Varela, Kauffman)
 - True, paradox values
- 3-valued w imaginary (Peirce, Lukasiewicz, etc)
 - Hold simple paradox as a value
- 3x1-valued (James)
 - Numbers up to exponentiation
- 4-valued (Kauffman, Hellerstein, Shoup)
 - Symmetrical, from 2-valued
 - Hold full contradiction, paradox as values

1-Valued Boundary Logic

- Nothing/Everything, Self/Universe
- Existence, objects
- Unique, Simplicity Itself
- Purely relative to observer/me
- Dominance, “Wire-OR”
- No opposition, no contradiction in arith
 - Belief, religion
- Pushing Nothing Around
 - Void + Void = Void
 - Void + Something = Something
 - Something + Something = Something

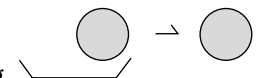

2-Valued Boundary Logic

- 2nd Distinction, no collapse
- Symmetrical, std boolean
- Contradiction in arith, paradox in algebra

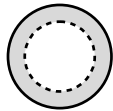

The Void

- Nothing (no-Thing), unique
- Not a spatial or mathematical object
 - not the vacuum, the empty set, a coord system
- No properties or attributes
 - not emptiness, no measure or dimensionality
- No consequences or effects
- Cannot be combined with anything
- Cannot be named or referenced
 - "The Tao that is named is not the Eternal Tao."

"God made everything out of nothing. But the nothingness shows through."
-- Paul Valéry

First Distinction

- First Thing -- Simplicity Itself
- Pure difference, discrimination
- Pure form, no interpretation yet
- Smallest possible, unavoidable step from the Void
- Both object and action (indication)

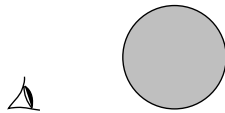

"The fundamental delusion of humanity is to suppose that I am here and you are out there." -- Yasutani Roshi

Second Distinction

- Two possibilities
 - a) outside - symmetrical, cardinality
 - b) inside - asymmetrical, ordinality
- Allows first contradiction, paradox

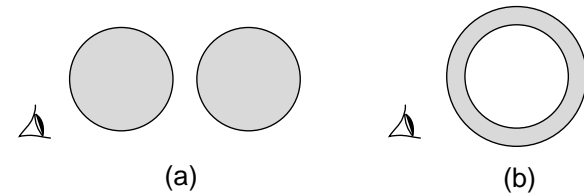

Combinational Logic is Timeless

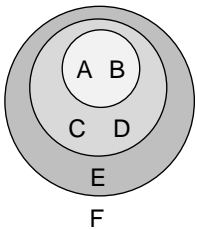
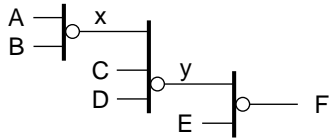

$$F = (((A \vee B) \vee C \vee D) \vee E)$$

Classic Paradoxes

- Epimenides (logic)
 - "I am lying." ("This statement is False.")
- Russell (set theory)
 - The set of all sets not containing themselves.
- the Barber (set theory or logic)
 - Barber shaves all men who don't shave themselves.
- Berry (number theory)
 - The smallest number not specifiable in less than N words.
- Gödel (logic/number/proof theory)
 - "This statement is unprovable."
- Turing (computability)
 - "This machine doesn't halt."

Self-Reference - the Origin of Time

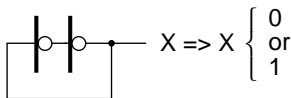

X in _____

X out _____

Autology (Memory)

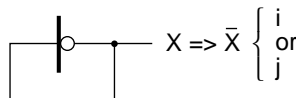

X in

X out

Paradox (Clock)

4-Valued Logic Holds Paradox

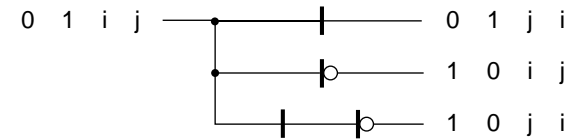

	0	1	i	j
0	0	1	j	i
1	1	1	1	1
i	j	1	j	1
j	i	1	1	i

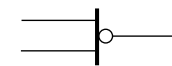

	0	1	i	j
0	1	0	i	j
1	0	0	0	0
i	i	0	i	0
j	j	0	0	j

i : Logic $:: \sqrt{-1}$: Reals

Logic

$x = \sim x$

$x = i \text{ or } j$

Real Numbers

$x = -1/x \quad (x^2 = -1)$

$x = \pm\sqrt{-1}$

Square Root of NOT

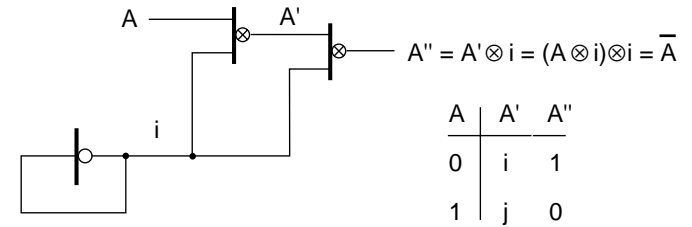
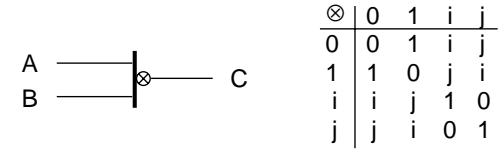

Eighth Root of NOT

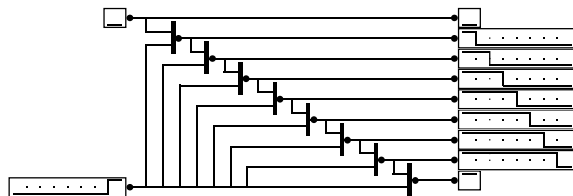

Memory & Superposition

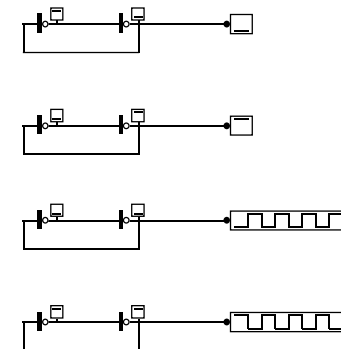

Linking Two NOTs - classical

$$\begin{array}{c|c} a & b \\ \hline 0 & 0 \\ 0 & 1 \\ 1 & 0 \\ 1 & 1 \end{array} \oplus \begin{array}{c|c} a' & b' \\ \hline 0 & 1 \\ 1 & 0 \\ 1 & 1 \\ 0 & 0 \end{array} \Rightarrow \begin{array}{c|c|c|c} a & b & a' & b' \\ \hline 0 & 1 & 1 & 0 \\ 0 & 1 & 1 & 1 \\ 1 & 0 & 0 & 1 \\ 1 & 0 & 0 & 0 \end{array} \Rightarrow \begin{array}{c|c|c} a & b' & n \\ \hline 0 & 0 & 1 \\ 1 & 1 & 1 \end{array}$$

$$\begin{bmatrix} 0 & 1 \\ 1 & 0 \end{bmatrix} \begin{bmatrix} 0 & 1 \\ 1 & 0 \end{bmatrix} \Rightarrow \begin{bmatrix} 1 & 0 \\ 0 & 1 \end{bmatrix}$$

Link Theory - Distributive Law

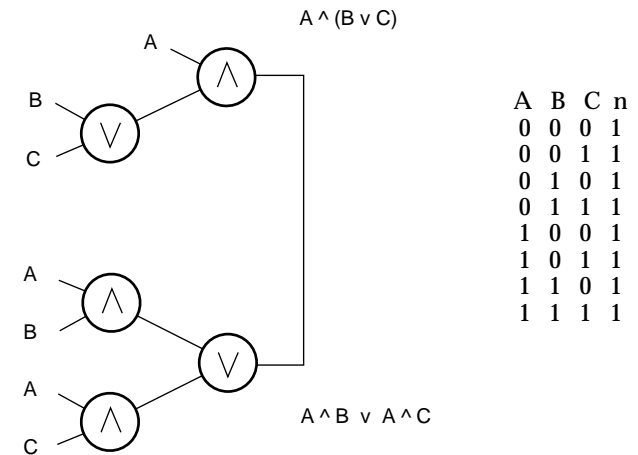

Link Theory - Cryptarithm

$$\begin{array}{r} \text{SEND} \\ + \text{MORE} \\ \hline \text{MONEY} \end{array} \Rightarrow \begin{cases} C_0 + D + E = Y + C_1 * 10, \\ C_1 + N + R = E + C_2 * 10, \\ C_2 + E + O = N + C_3 * 10, \\ C_3 + S + M = O + C_4 * 10, \\ C_4 = M, C_0 = 0 \end{cases}$$

where $S, E, N, D, M, O, R, Y \in \{0-9\}$
and $C_i \in \{0,1\}$

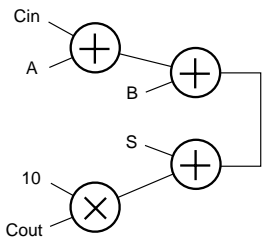

$$Cin + A + B = S + Cout * 10$$

Link Theory - Cryptarithm solution

$$\begin{array}{r} \text{SEND} \\ + \text{MORE} \\ \hline \text{MONEY} \end{array} \Rightarrow \begin{cases} C_0 + D + E = Y + C_1 * 10, \\ C_1 + N + R = E + C_2 * 10, \\ C_2 + E + O = N + C_3 * 10, \\ C_3 + S + M = O + C_4 * 10, \\ C_4 = M, C_0 = 0 \end{cases}$$

where $S, E, N, D, M, O, R, Y \in \{0-9\}$
and $C_i \in \{0,1\}$

$$\Rightarrow \begin{array}{r} 9567 \\ + 1085 \\ \hline 10652 \end{array}$$

Linking Two Sqrt(NOT)s - interference

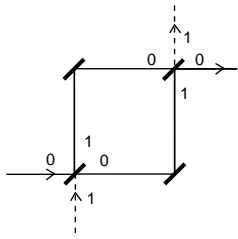

$$\begin{bmatrix} 1 & 1 \\ -1 & 1 \end{bmatrix} \begin{bmatrix} 1 & 1 \\ -1 & 1 \end{bmatrix} \Rightarrow \begin{bmatrix} 0 & 2 \\ -2 & 0 \end{bmatrix}$$

a	b	n	⊕	a'	b'	n'
0	0	1		0	0	1
0	1	1		0	1	1
1	0	-1		1	0	-1
1	1	1		1	1	1

 \Rightarrow

a	ba'	b'	n'
0	0	0	1
0	0	1	1
0	1	0	-1
0	1	1	1
1	0	0	-1
1	0	1	-1
1	1	0	-1
1	1	1	1

 \Rightarrow

a	b'	n'
0	0	0
0	1	2
1	0	-2
1	1	0

Connecting Physics & Computing

- Sqrt(NOT) - logic and physics
- Link Theory - relational database -> QM matrices
- NMR Quantum computer (Gershenfeld & Chuang)
 - “coffee cup” + magnetic fields
 - ≤ 4 Qbit ops, ~1 Hz. operational at room temperature
 - table-top version?
 - matter in states never before seen
 - <http://feynman.stanford.edu/qcomp/>

“Some Principle uniquely right and uniquely simple must, when one knows it, be also so compelling that it is clear the universe is built, and must be built, in such and such a way, and that it could not possibly be otherwise.”

-- John A. Wheeler in Gravitation